

NYLON/STEEL FIRE ESCAPE LADDER**MODEL EL52**

This nylon/steel Fire Escape Ladder is easy to use, and provides a reliable means of escape through a second floor window during a home fire.

FEATURES AND BENEFITS

- For use in two-story homes
- Strong nylon construction
- Fully assembled, ready to use
- Slip-resistant epoxy coated rungs
- Large hooks secure easily to windowsills
- Steel rung stabilizers on all rungs
- Ladder complies with the ASTM Standard F 2175-02. 375 lb. (170 kg) Ladder load rating
- Ladder is 14 feet (4.3 meters) in length.

⚠ WARNING!

- Read instructions for use immediately upon purchase.
- Close doors before opening any windows to prevent fire from being drawn into the room.
- Keep body close to ladder.
- Unless absolutely necessary, do not carry a child when using this ladder.
- Do not carry pets or miscellaneous objects when using this ladder.
- Instruct family members to use this portable escape ladder only when the primary escape path (that is, the main exit) is blocked or unsafe to use.
- This portable escape ladder is not a toy or recreational device. Instruct children that the ladder is to be used only in an emergency.
- For use only in windows that are structurally safe for the intended load.
- Not recommended for use with storm windows or other windows that do not open to the recommended minimum dimensions [20 inches (51 cm) wide and 32 inches (81 cm) high].
- Do not use above a 2 story height.
- Do not attempt to deploy the ladder from windows that are obstructed by furniture, radiators, air conditioning units, or security devices such as grilles or bars (without inside release mechanisms).
- Do not attempt to deploy the ladder into flames.
- Check for outside obstructions such as electric lines, telephone wires, or fences.
- Do not attempt to use the ladder if the windowsill does not meet the size range specified. The windowsill width should be between a minimum of 6 inches (15 cm) and a maximum of 10 inches (25 cm).
- Always plan and practice drills to ensure that occupants are familiar enough for proper use.
- This ladder is intended to supplement (not replace) the more important fire protection principles of fire drills, emergency evacuation plans, smoke alarms, fire extinguishers, etc.
- This ladder should be periodically inspected for damage, loosening of any items, or significant deterioration of the materials of construction.
- This ladder is designed for use by one person at a time.
- Store the ladder in a convenient location near the exit window; for example, under a bed, in a closet, etc.

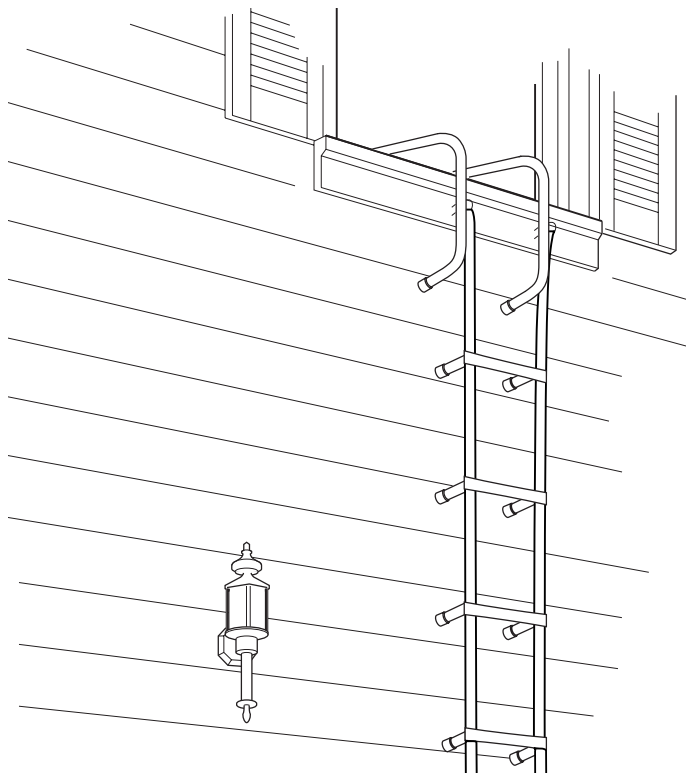

IMPORTANT!

TO WORK PROPERLY IN A FIRE EMERGENCY, THIS LADDER MUST:

Be Stored Where It Is Easy To Reach Quickly...

Do not store the ladder on another floor of your home. If you have more than one second-floor room requiring an alternate means of escape, put a fire ladder in each room.

Store the ladder where it can be immediately accessed--near the window, under a bed, or in the front part of a closet.

Make sure nothing blocks you from reaching the ladder. In a fire you have limited time to react and take action.

Store the ladder in its original box to keep it from becoming tangled.

Be Used On A Suitable Window...

This ladder is intended for use in windows that are structurally safe for the intended load.

The ladder must be used from the correct height, and there should be no obstructions along the ladder path to the ground.

This ladder is intended only for second-floor windows no higher than 16 feet (4.9 meters) from the ground.

The windowsill must be no narrower than 6 inches (15 cm) and no wider than 10 inches (25 cm).

The windowsill must be in good condition (no rotted wood, loose boards, etc.).

The window must open easily and completely. Storm windows, screens or other types of multi-track windows can make it difficult to use this ladder in an emergency.

The window should not be blocked by furniture or security devices like grilles or bars.

For details on choosing a suitable window, see the "Choosing A Window" section of this manual.

Be Properly Secured To The Windowsill Before You Start Climbing Down...

To properly support your weight and provide the needed stability while you climb down, the ladder must be properly attached to the windowsill.

Make sure the sill hooks rest securely on the windowsill.

Make sure the folding crosspiece between the sill hooks is straight, and the straps do not tangle as you lower the ladder out of the window.

Choosing A Window

⚠ WARNING!

This escape ladder is not intended for use from second floor windows directly above first floor windows. The rung stabilizers could break a first-floor window and cause injury.

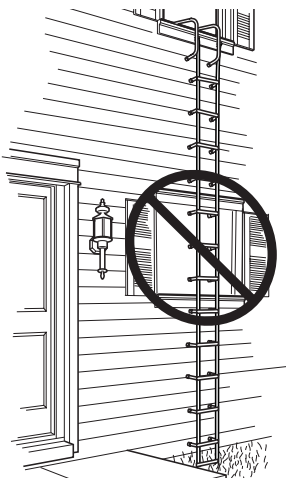

Do not use from a second floor window directly above a first floor window.

⚠ WARNING!

You must test fit this ladder on your chosen escape window before storing it. In a fire emergency you will not have time to determine whether or not a particular window is suitable, and using the ladder on an unsuitable window could result in injury or death.

1. The ladder should be used ONLY from second floor windows no more than 16 feet (4.9 meters) from the ground.

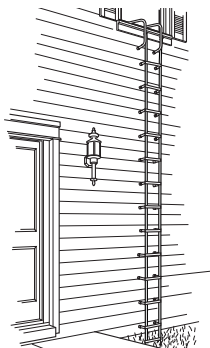

Use ONLY from second floor windows no more than 16 feet (4.9 meters) from the ground.

2. The window should be at least 20 inches (51 cm) wide and 32 inches (81 cm) high to give you enough clearance to exit safely.

The windowsill width should be between a minimum of 6 inches (15 cm) and a maximum of 10 inches (25 cm). Measure windowsill from outside to inside. DO NOT USE THIS FIRE ESCAPE LADDER ON WINDOWSILLS THAT ARE TOO LARGE OR TOO SMALL FOR THE HOOKS.

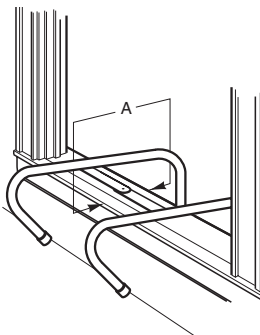

DIMENSION A:
The windowsill width should be between a minimum of 6" (15 cm) and a maximum of 10" (25 cm).

3. DO NOT USE ON A DAMAGED OR WEAK WINDOWSILL. Check windowsill for wear, rotted or loose wood, or damage. Consult a contractor or replace windowsill BEFORE attempting to hook the fire escape ladder to a damaged windowsill. This ladder is intended for use in windows that are structurally safe for the intended load.
4. For safest use, there should be a clear path from the window all the way to the ground. BEFORE STORING THE LADDER FOR AN EMERGENCY: From outside of your home, check below the window for any obstructions. Check for trees, bushes, plants, windows, house fixtures, or any other objects in the direct path below the chosen window.
5. Make sure the window you choose opens easily and completely. In an emergency, every minute counts.

Securing the Ladder After Use

1. Lay the box on the floor with the lid folded open.

2. Stretch the ladder out on the floor, with the rung standoffs facing up towards you placing the rungs as close as possible next to each other. Assemble the rungs into the box keeping the the standoffs facing upward.

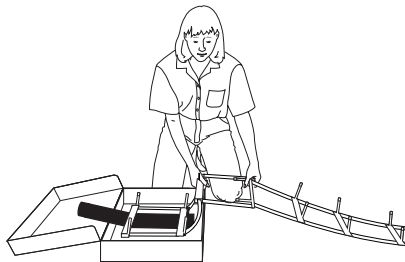

3. Use the plastic strap (attached to the last rung) to wrap and secure the rungs. This will minimize the chance of the ladder becoming tangled when you remove it from the box in an emergency.

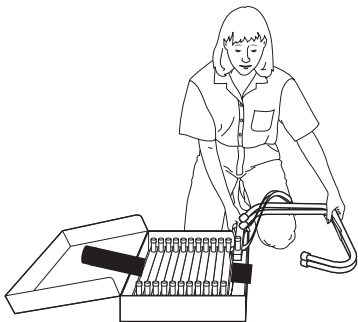

4. Place the folded sill hooks on top of the rungs, between the standoffs as shown in the diagram.

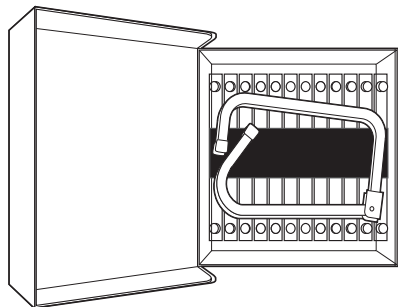

5. Store the escape ladder in an accessible location. Be sure nothing blocks your access to the ladder.

How to Use in a Fire Emergency

⚠WARNING!

This fire escape ladder is not a toy or recreational device. Use it only in a fire emergency.

IMPORTANT!

It is strongly recommended that children and elderly adults be assisted by an adult if at all possible when using this ladder in a fire emergency.

⚠WARNING!

THIS LADDER IS DESIGNED FOR USE BY ONE PERSON AT A TIME.

1. Before you open the window, close the door leading out of the room to prevent the fire from being drawn into the room.

2. Remove the ladder from the box and unfold sill hooks so the folding crosspiece is straight and positioned towards you.

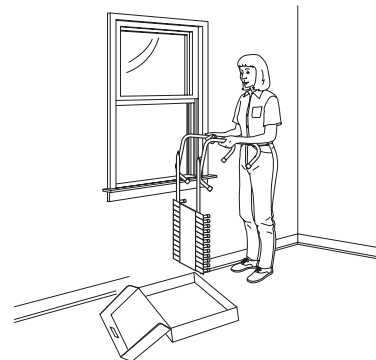

3. Place the sill hooks firmly over the windowsill and pull the release strap to deploy the ladder.

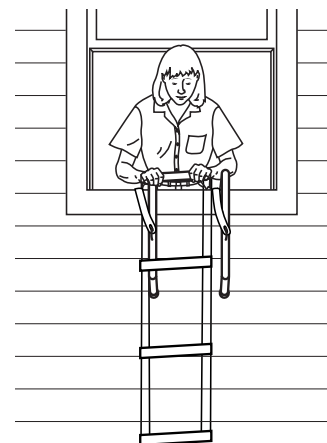
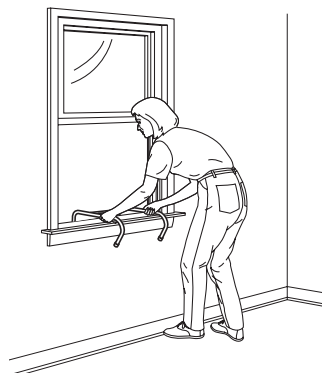

4. Exit carefully through the window and place your feet on the first rung. Hold onto the window frame until your weight is evenly distributed on the ladder. Climb down, keeping your body close to the ladder.

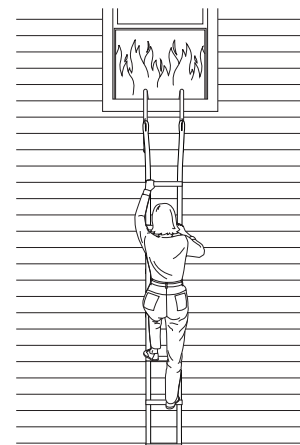

What Fire Escape Ladders Cannot Do

- This fire escape ladder is NOT a means of protection against fire. It will not warn or alert you to a fire or of any other type of emergency. It is intended to be used as an alternate escape means in a fire emergency only.
- This fire escape ladder is NOT intended to be the main exit for escape in an emergency. Instruct family members to use the fire escape ladder as a last resort, ONLY when their main exit is blocked, not accessible, or unsafe to use.
- This fire escape ladder is NOT a toy or recreational device. It is intended to be used as a supplemental emergency escape device ONLY. Instruct children not to use this fire escape ladder for any reason, except in an emergency.
- DO NOT carry any pets or other objects when using the ladder.
- Unless absolutely necessary, do not carry a child when using this ladder.
- This portable fire escape ladder does not meet your local codes as a primary means of exit from multi-family dwellings. It is not intended to replace fire escapes in multi-family residences, institutions, or rental properties. This ladder is intended for use as a means of escape from residential buildings, and may supplement the primary means of exit required by codes and other local regulations.
- This fire escape ladder is NOT intended for use from rooms above a second-floor level. DO NOT use from rooms above a second-floor height. The ladder is 14 feet (4.3 meters) long and is NOT intended for escape from rooms with windowsills higher than 16 feet (4.9 meters) from the ground.
- This fire escape ladder is NOT intended to be hooked onto gutters, siding, or any other interior or exterior fixture. It is ONLY intended to be hooked to windowsills.

Limited Warranty

BRK Brands, Inc., ("BRK") the maker of First Alert® brand products warrants that for a period of six years from the date of purchase, this product will be free from defects in material and workmanship. BRK, at its option, will repair or replace this product or any component of the product found to be defective during the warranty period. Replacement will be made with a new or remanufactured product or component. If the product is no longer available, replacement may be made with a similar product of equal or greater value. This is your exclusive warranty.

This warranty is valid for the original retail purchaser from the date of initial retail purchase and is not transferable. Keep the original sales receipt. Proof of purchase is required to obtain warranty performance. BRK dealers, service centers, or retail stores selling BRK products do not have the right to alter, modify or any way change the terms and conditions of this warranty.

This warranty does not cover normal wear of parts or damage resulting from any of the following: negligent use or misuse of the product, use contrary to the operating instructions, disassembly, repair or alteration by anyone other than BRK or an authorized service center. Further, the warranty does not cover Acts of God, such as fire, flood, hurricanes and tornadoes.

BRK shall not be liable for any incidental or consequential damages caused by the breach of any express or implied warranty. Except to the extent prohibited by applicable law, any implied warranty of merchantability or fitness for a particular purpose is limited in duration to the duration of the above warranty. Some states, provinces or jurisdictions do not allow the exclusion or limitation of incidental or consequential damages or limitations on how long an implied warranty lasts, so the above limitations or exclusion may not apply to you. This warranty gives you specific legal rights, and you may also have other rights that vary from state to state or province to province.

How to Obtain Warranty Service

Service: If service is required, do not return the product to your retailer. In order to obtain warranty service, contact the Consumer Affairs Division at 1-800-323-9005, 7:30 AM - 5:00 PM Central Standard Time, Monday through Friday. To assist us in serving you, please have the model number and date of purchase available when calling.

303 Nelson Avenue, Neosho, MO 64850-8806.

First Alert® is a registered trademark of the First Alert Trust.